

The Essential Signal Generator Guide

Building a Solid Foundation in RF – Part 2

Introduction

Having a robust and reliable high-speed wireless connection helps win and retain customers. It has quickly become a requirement for doing business. In order to meet this requirement, you need the right signal generator.

As frequency spectrum is a finite resource, complex modulation schemes are needed to increase spectral efficiency, which allows for far higher data rates. Unfortunately, complex modulation schemes depend on accurate and stable signal generators to work effectively. With all the specifications and features available out there, getting the right signal generator for the job can be a daunting task.

In this second part of our two-part white paper, we help you gain a sound understanding of various modulation schemes, the importance of spectral purity, and how distortion can help you. We will also explore how you can use smart software to significantly improve your productivity.



Contents

In Part 2 of our two-part eBook, we will highlight more advanced features such as modulation, spectral purity, and distortion. We introduced the signal generator and looked at basic specifications such as power, accuracy, and speed in [Part 1](#).

Section 5. IQ Modulation

Learn about basic I/Q modulation and its key characteristics, and stress-test your designs with I/Q impairments.

Section 6. Spectral Purity

Spectral purity performance is a key factor in obtaining accurate measurements. Understand phase noise requirements in signal generation.

Section 7. Distortion Performance

Get to know the different types of distortions and why they matter to your measurements.

Section 8. Software

Software is a productivity multiplier. With the right software, you can quickly set up and test with just a few clicks.



Section 5 - IQ Modulation

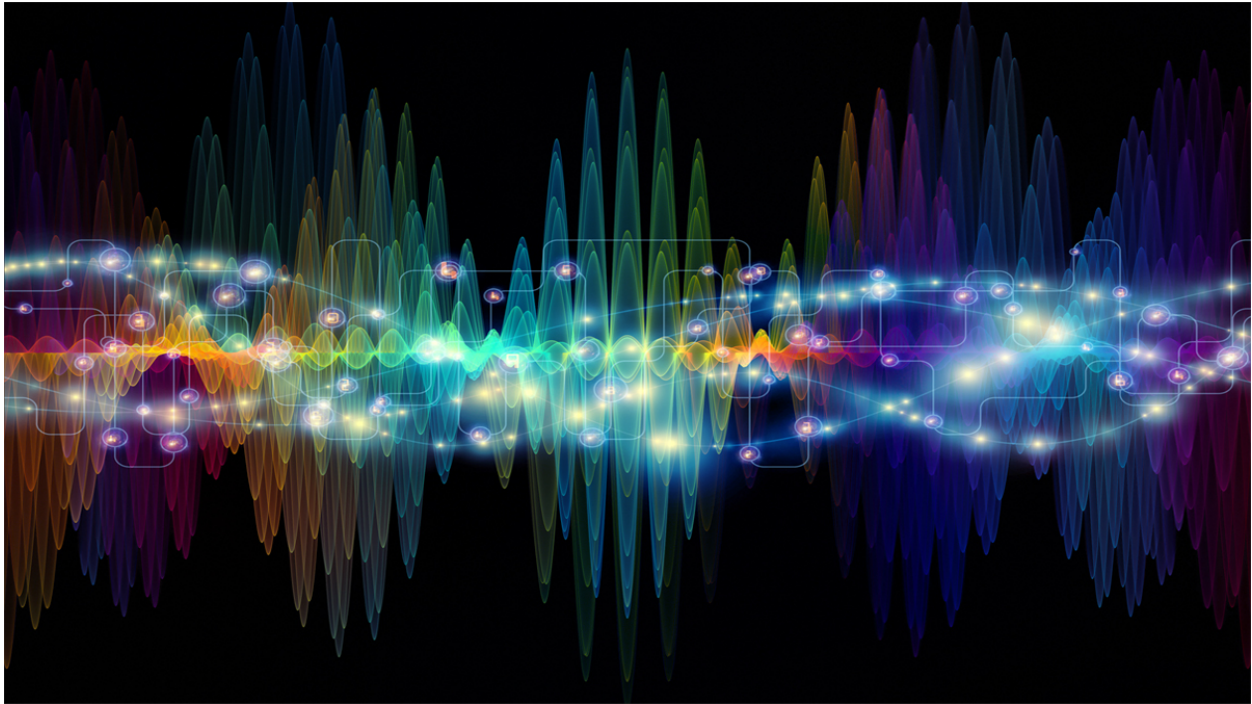

Let's illustrate the concept of IQ Modulation with an example. It is Friday, and you and your buddies decide to head over to a popular Mexican restaurant for lunch. You arrive early and find a long table that can seat all 10 people in your party. As you place your orders, more people enter the restaurant. While waiting for your food, everyone starts talking about their weekend plans. You try to ask Bill – seated at the far end of the table from you – if he has found a new spot for fly fishing. But you cannot hear him due to noise in the restaurant and the fact he is seated far away. You begin using your arms and facial expressions to try to communicate. Bill does the same.

You and Bill are essentially modulating your bodies to communicate. The efficacy of your communication depends on how well you use your hands, arms, and facial expressions. This is called modulation quality.

Modulation quality is a major consideration for signal generators prior to performing your measurements. It is important to ensure you test your Device Under Test's (DUT) performance instead of the performance of the signal generator.

What is Modulation?

Modulation is like waving your arms to convey messages to Bill. In the world of electrical signals, modulation is modifying a high-frequency signal to convey information. Just like your arms carry messages, the high-frequency signal carries information.

Why do we modulate signals? Well, modulation allows you to “talk” to Bill who is sitting at the far end of the table in a noisy restaurant. For digital communications, modulation also allows you to transmit significantly more data using narrow frequency bandwidths.

I/Q Modulation

The basic modulation schemes are amplitude, frequency, and phase modulation. Modulating signals can be expressed in the polar form (vector) with magnitude and phase. I/Q Modulation is widely used in digital communication due to its spectrum efficiency. IQ Modulation uses two carriers, one is known as the in-phase (I) component, and the other is the quadrature (Q) component that is phase-shifted by 90° from the in-phase component as shown in Figure 5.1.

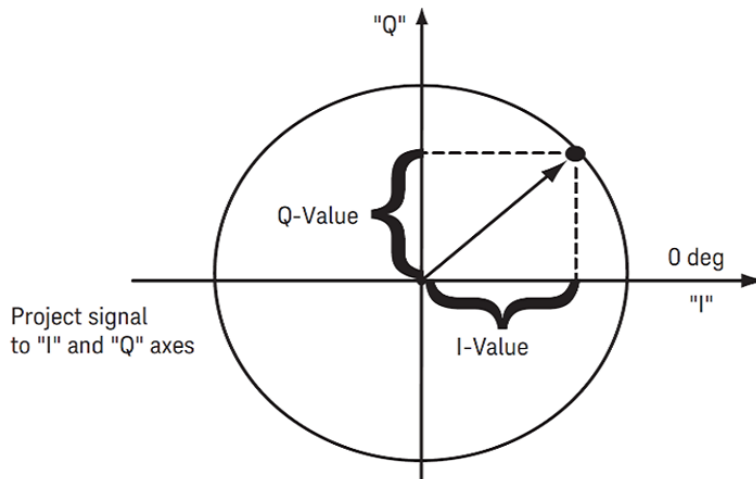

Figure 5.1: I/Q phasor diagram

I/Q modulation's main advantage is the symmetric ease of combining independent signal components into a single composite signal, and later splitting the composite signal into its independent components.

In a digital transmitter, I and Q signals are mixed with the same local oscillator (LO) but with a 90-degree phase shifter placed in one of the LO paths, as shown in Figure 5.2. This 90-degree phase shift makes the I and Q signals orthogonal to each other so that they do not interfere with each other.

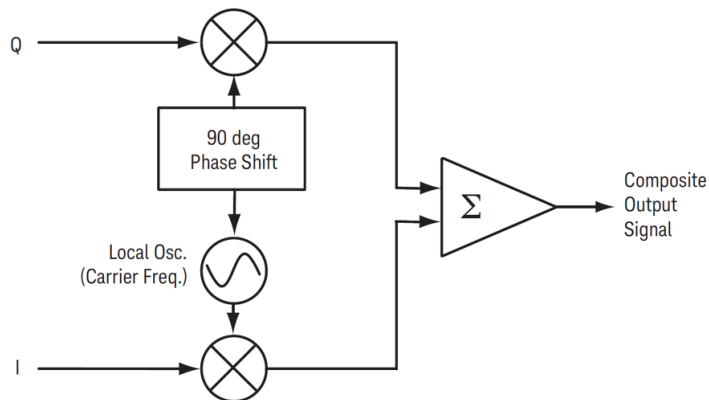

Figure 5.2: Baseband IQ modulation



To learn more about the basics of digital modulation, refer to "[Digital Modulation in Communications Systems – An Introduction](#)".

Key IQ Modulation Parameters

Modulation Schemes

Changes to vector signals on an I/Q diagram can be shown in magnitude, phase, frequency, or some combination of those. These magnitude and phase changes result in different modulation formats. As the data conveyed is in binary, the number of constellation points must be a power of 2. The most fundamental digital modulation formats are:

- PSK (*phase-shift keying*)
- FSK (*frequency-shift keying*)
- ASK (*amplitude-shift keying*)
- QAM (*quadrature amplitude modulation*)

Constellation and Symbols

A constellation diagram shows the available symbols of a QAM format. In the case of a 16-QAM format, each symbol represents one possible combination of four binary bits. A total of 16 possible combinations exists for these four binary bits. In other words, each symbol represents four bits.

To increase data bandwidth, we can increase the number of bits each symbol represents, which will increase spectral efficiency. However, as the number of symbols increases in the constellation diagram, the space between the symbols decreases. The symbols are closer together and are thus more prone to errors due to noise and distortion. Figure 5.3 shows increases in symbol density when changing from a 16-QAM format to a 64-QAM format.

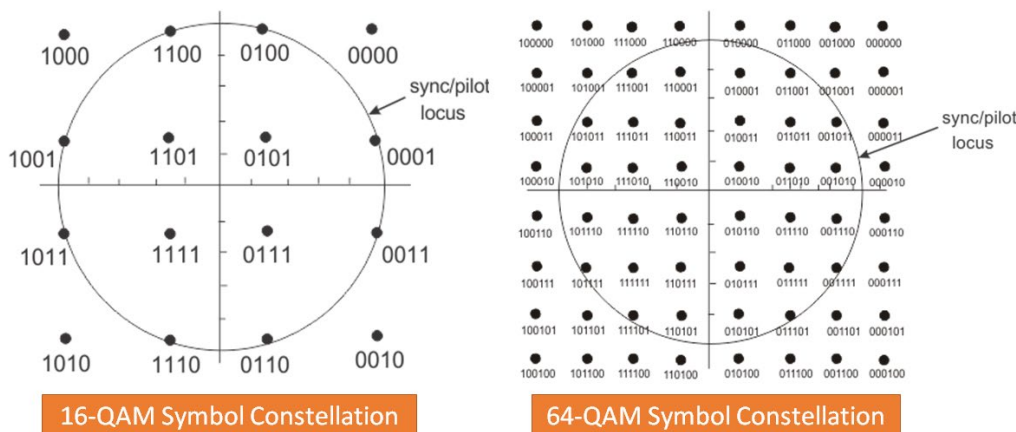

Figure 5.3: Constellation of 16-QAM and 64-QAM formats

Digital Modulation Types - Variations

Communications systems use three main variations on the basic modulation schemes. These variations avoid the I/Q signal trajectories from going through zero (the center of the constellation). This results in power efficiency advantages.

- IQ offset modulation: OQPSK used in ZigBee 2450-MHz band
- Differential modulation: $\pi/4$ DQPSK used in Bluetooth 2.0+ EDR
- Constant envelope modulation: GMSK used in GSM, 2-FSK used in Wi-SUN

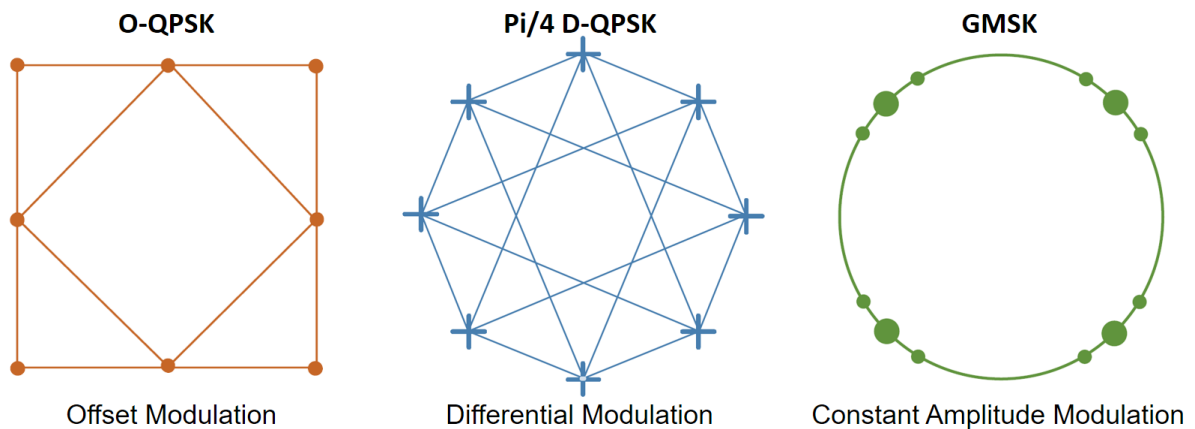

Figure 5.4. IQ modulation variations

Orthogonal frequency division multiplexing (OFDM) is another popular modulation scheme. Many of the latest wireless and telecommunication standards such as digital broadcasting, xDSL, wireless networks, 4G and 5G new radio (NR) cellular technologies have adopted this tactic.

OFDM employs multiple overlapping radio frequency carriers. Each carrier operates at a carefully chosen frequency that is orthogonal to the others, to produce a transmission scheme that supports higher bit rates due to parallel sub-carrier operation. In addition, OFDM provides a combination of spectral efficiency, flexibility, and robustness.

Bit Rate vs. Symbol Rate (Baud Rate)

Bit rate is the frequency of a system bit stream. Symbol rate is the bit rate divided by the number of bits that can be transmitted with each symbol. For example, QPSK is two bits per symbol. The symbol rate of QPSK is half of its bit rate. The signal bandwidth and symbol rate are in direct proportion.

Symbol rate = bit rate / the number of bits transmitted with each symbol

Error Vector Magnitude (EVM)

An error vector is the vector difference between the ideal I/Q reference signal and the measured signal. EVM is simply the magnitude of this error vector. The error vector is the result of phase noise from local oscillators, noise from power amplifiers, I/Q modulator impairments, etc.



For details on OFDM signal operation, refer to our application notes on “[Custom OFDM Signal Generation](#)” and “[Making Custom OFDM Measurements](#)”.

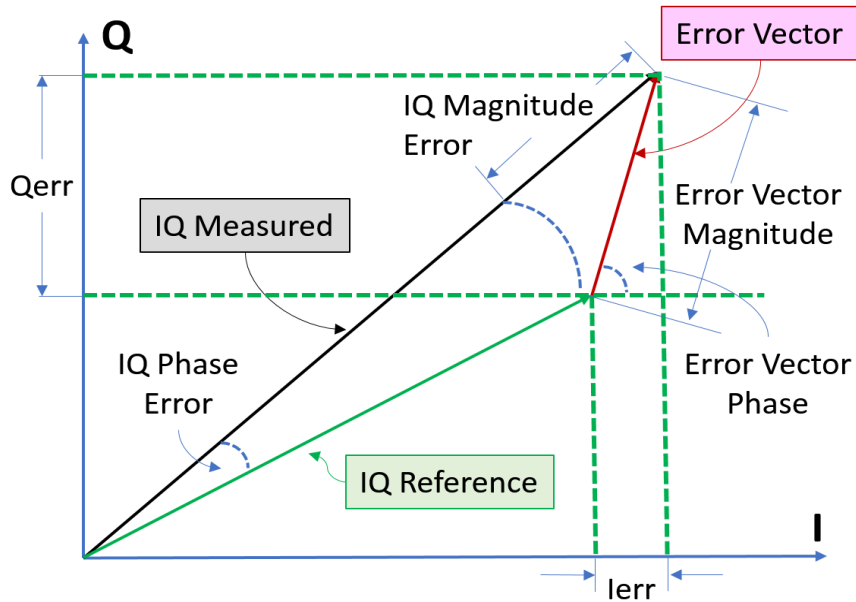

To learn more about vector modulation analysis, refer to the Application Note “Using Vector Modulation Analysis in the Integration, Troubleshooting, and Design of Digital RF Communications Systems”.

Figure 5.5: Graphical representation of the error vector



To ensure you are evaluating your DUT's EVM performance, your signal generator's EVM performance needs to be 5 to 10 dB better than your DUT's EVM expected performance.

For example, the 802.11ax transmitter EVM standard requirement for 1024 QAM is -35 dB. The residual EVM floor of signal generators used in design validation should be lower than -45 dB. However, for production test, EVM performance of less than -40 dB is good enough.

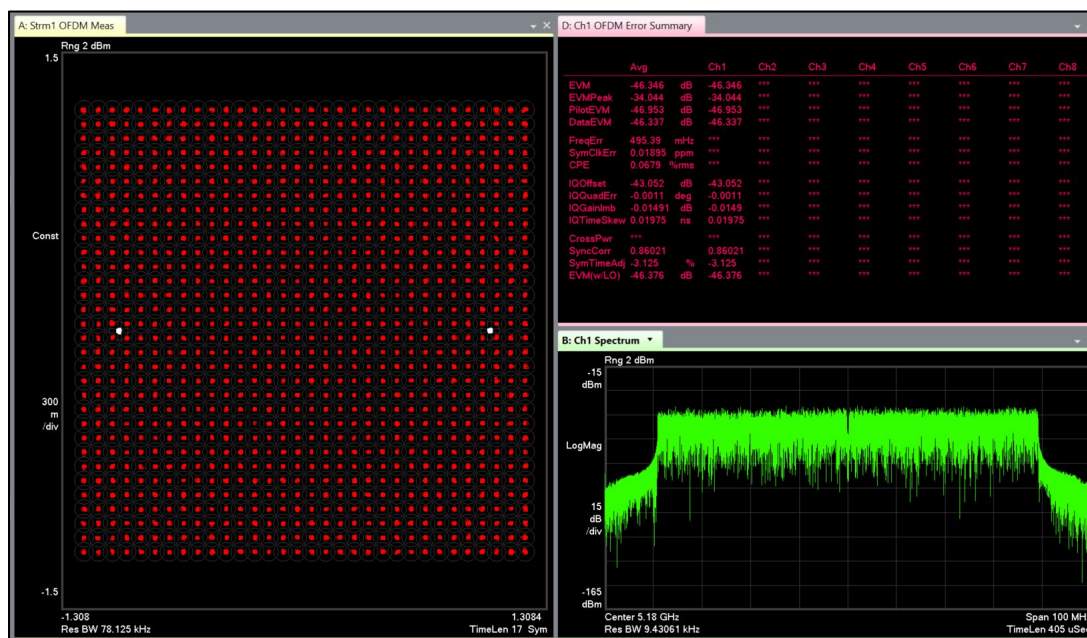

Figure 5.6: 802.11ax Constellation diagram and error summary

I/Q Impairments

I/Q impairments may crop up in your designs. When they do, you will need to simulate these impairments to stress-test your designs or compensate for time and amplitude variations in the signal path. Your signal generator has the ability to generate I/Q impairments. Use the following I/Q adjustments to simulate the impairments you need. A summary of I/Q adjustments uses and effects appears in table 5.1.

- **I/Q offset:** DC offsets of the I and Q signals
- **Quadrature angle:** Offset the phase of the Q signal relative to the phase of the I signal
- **I/Q skew:** A relative time delay between the I and Q signals
- **I/Q gain balance:** The I signal amplitude relative to the Q signal amplitude
- **I/Q phase:** The absolute phase of the internal I/Q channel by rotating both I and Q

I/Q adjustment	Effect	Impairment
Offset	Carrier feedthrough	DC offset
Quadrature angle	EVM performance	Phase skew
	I/Q images	I/Q path delay
I/Q skew	EVM error	High sample rate phase skew or I/Q path delay
I/Q gain balance	I/Q amplitude difference	I/Q gain ratio
I/Q phase	I/A phase rotation	RF phase adjustment

Table 5.1: I/Q Adjustments Uses



Other than I/Q adjustments, you can also add phase noise impairments or AM/FM to a carrier to simulate an imperfect signal or add AWGN to a modulated signal as a source of interference for your design verification.

Download the latest white paper:

- [Making Noise in RF Receivers](#)
- [Understanding Phase Noise Needs and Choices in Signal Generation](#)

Section 6. Spectral Purity

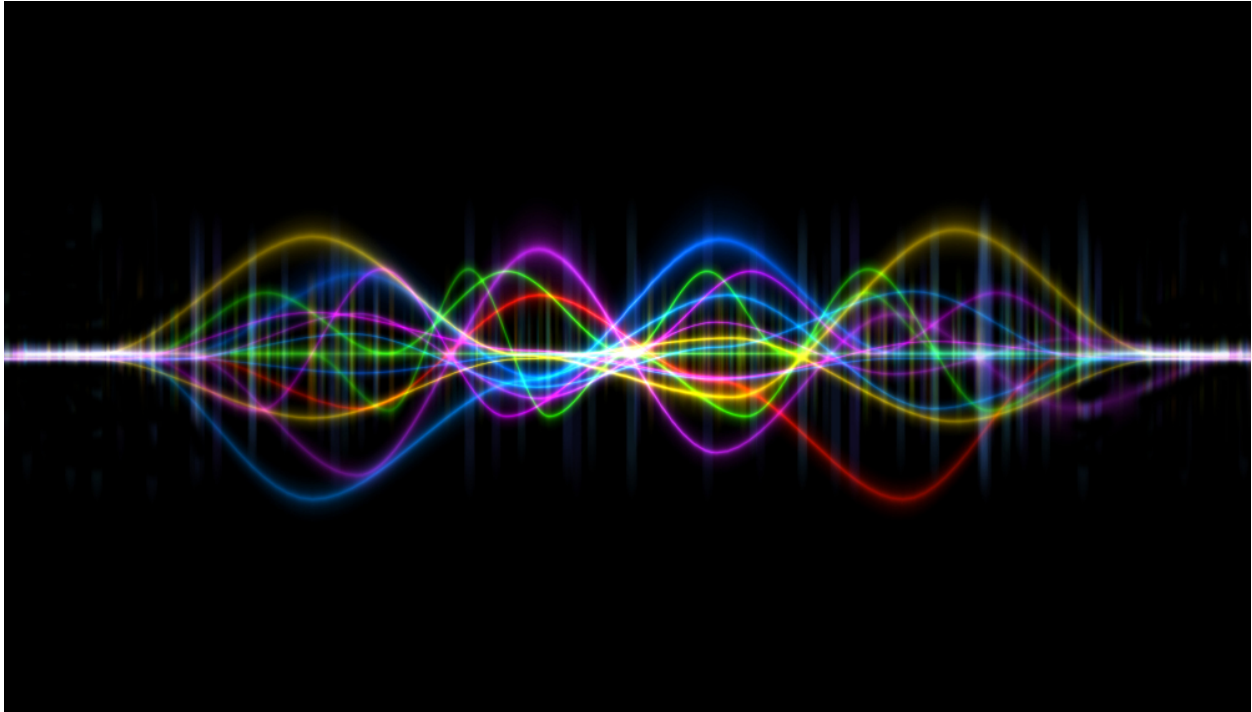

To illustrate the concept of spectral purity, let's say Dave arrived at your house and pressed the doorbell. He waited for a couple of minutes at the door. A mild-mannered young man opened the door, looked at Dave, and pointed to the living room. Dave entered the living room, put his piano-tuning forks aside, and started playing the piano. Dave came to the house to tune the grand piano.

As Dave played each tone, he struck the tuning fork. The fork emitted a serene, almost perfect tone that filled the air each time Dave hit it. Using this perfect tone as a reference, Dave tuned the piano.

A signal generator works like a tuning fork, emitting an almost perfect signal that is used in many diverse RF applications such as clock references, RF power amplifier testing, adjacent channel sensitivity testing, and many more. The integrity of the signal generator output is what we refer to as spectral purity.

Robust signal generators output signals with as little imperfection as possible. However, random amplitude fluctuations and phase fluctuations occur in real-life waveforms. A waveform has a phase shift and amplitude shift in the time domain. In the frequency domain, the signal has both amplitude and frequency modulation. The major measurements of spectral purity are phase noise, harmonics, and spurs.

In this section, you will learn what spectral purity is and why it matters.

Harmonics & Spurious

Both harmonics and spurious are deterministic (non-random) signals generated from mixing or dividing signals to get the output signal. These are unwanted frequencies generated in the RF systems. The harmonics appear as integer multiples of the carrier frequency, while the spurious frequencies appear as a non-integer multiple of the carrier frequency.

Figure 6.1 shows a carrier frequency at 1 GHz and its harmonics and spurious. The 2nd harmonic (marker 2) is -64.36 dBc relative to the fundamental carrier (marker 1), and the 3rd harmonic (marker 3) is -72.83 dBc. Markers 4 and 5 indicate spurs.

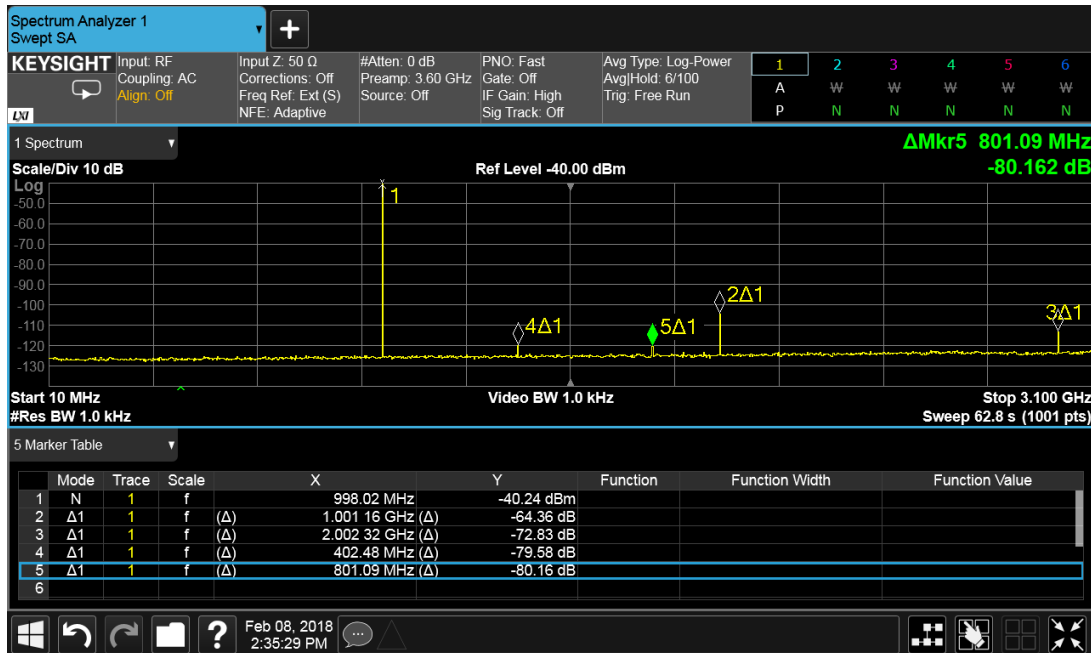

Figure 6.1: A continuous wave (CW) signal at 1 GHz generated by a signal generator



Choose a high-dynamic range signal analyzer to measure harmonics and spurs. Otherwise, the harmonics and spurs you detect may be from the signal analyzer instead of the device under test (DUT).

Phase Noise

Phase noise is a frequency-domain view of the noise spectrum around an oscillator signal. It describes the frequency stability of an oscillator. Frequency stability can be broken into two components: long-term stability and short-term stability, as shown in Figure 6.2 below.

Table 6.1 below shows a comparison between long-term and short-term frequency stability. Short-term variations contribute to phase noise while long-term drifts impact accuracy.

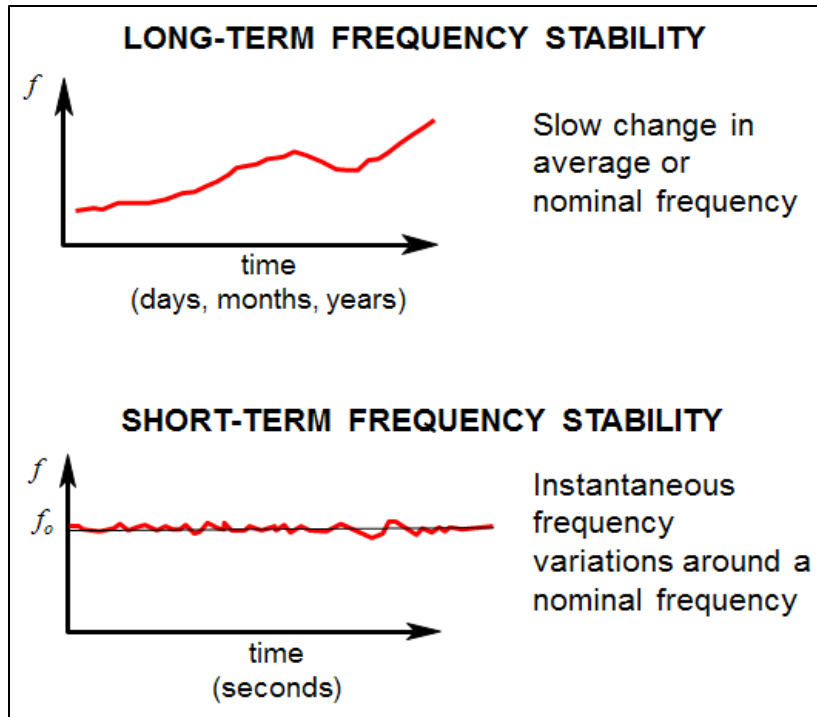

Figure 6.2: Long-term and short-term frequency stability

	Short-term frequency stability	Long-term frequency stability
Period	Seconds	Minutes - years
Terminology	Random noise: phase noise, jitter Deterministic: spurious	Accuracy, drift, aging
Measurement	$\mathcal{L}(f)$ curves, integrated totals, spot measurements, jitter (p-p)	Often determined by a frequency reference

Table 6.1: Long-term and short-term frequency stability

The most common way to define the amount of phase noise is to define the amount of single-sideband (SSB) power contained within a one-hertz bandwidth at a specific frequency away from the main frequency. The equation below explains:

$\mathcal{L}(f)$ = Noise power in a 1-Hz Bandwidth / main frequency power
where $\mathcal{L}(f)$ has units of dBc/Hz

Figure 6.3 shows an SSB phase noise measurement of a signal generator. The yellow trace shows instantaneous power measurements while the blue trace is the average result.

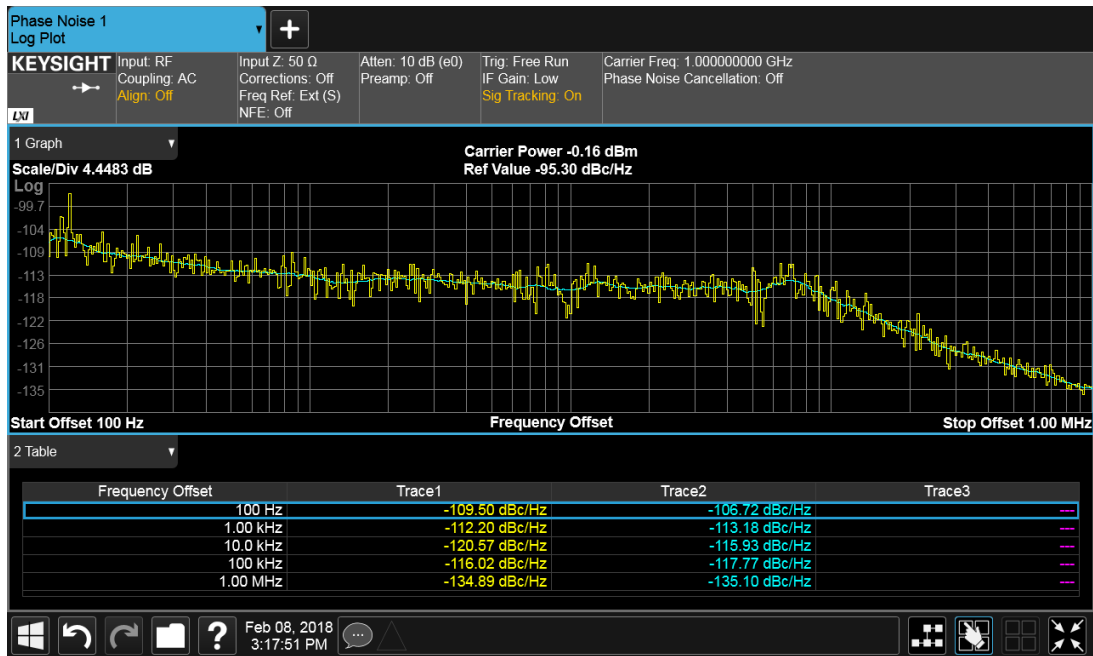

Figure 6.3: SSB phase noise measurement with a log plot and decade table



To measure phase noise effectively, you will need to use a signal analyzer with phase noise performance that is at least -10 dB better than the expected phase noise of your signal. Otherwise, the spectrum analyzer's LO's phase noise will contribute to the measured phase noise.

When Phase Noise Matters

Understand the impact of phase noise on your measurements to get just the right amount of performance for your test. High phase noise obscures weak signals that are close to the main frequency.

Radar Applications

Radar systems require excellent phase noise performance. A radar transmits pulses at a specific frequency and measures changes in the returning pulse's frequency. Changes in frequency tell us about the velocity of the object based on the Doppler effect. If the object moves very slowly, the frequency shift of the returning pulse is small.

In Figure 6.4, the returning pulse of a moving object is the "signal of interest" and the returning pulse of a fixed object (e.g. ground) is the "interfering signal". The radar receiver will be unable to identify the moving object if the downconverted signal of interest is masked by the phase noise.

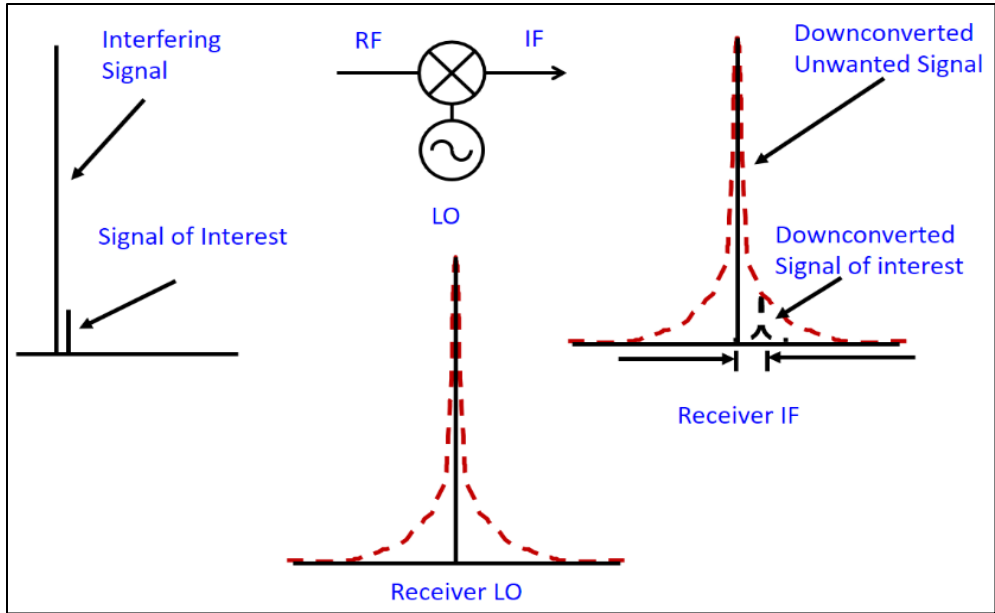

Figure 6.4: Poor LO phase noise affects receiver sensitivity.

Digital Modulation

Figure 6.5 shows a simplified Quadrature Phase Key Shifting (QPSK) digital receiver block diagram. The phase noise of the LO signal is translated into the output of the mixers. Phase noise causes radial smearing of the symbols (shown in green) on the constellation diagram. For closely spaced symbols in a higher order modulation scheme (e.g. 256 QAM), radial smears can overlap and result in bad receiver sensitivity.

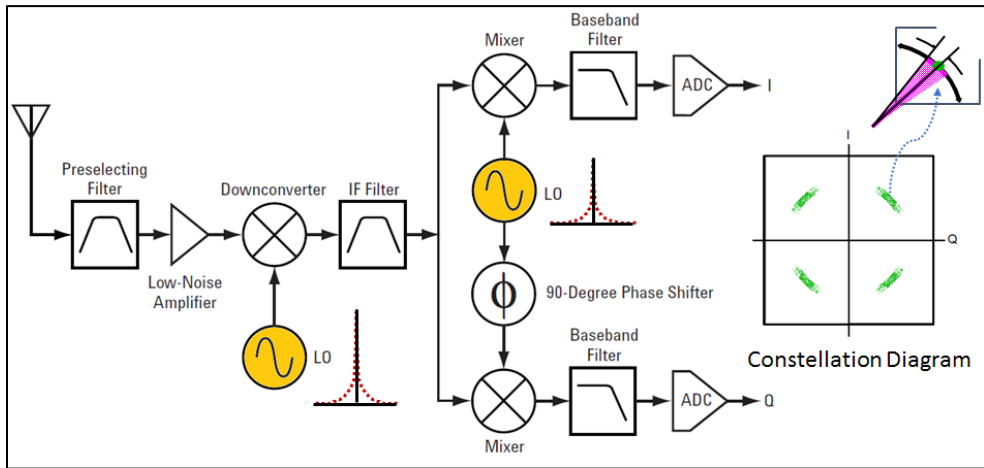

Figure 6.5: A simplified digital receiver block diagram

Orthogonal Frequency-Division Multiplexing (OFDM)

OFDM is a popular modulation scheme for wideband digital communication. OFDM uses many closely spaced orthogonal sub-carrier signals to transmit data in parallel (shown in Figure 6.6). LO phase noise will cause the sub-carriers' phase noise to spread into other sub-carriers as interference. The phase noise will degrade the modulation quality of the OFDM signal.

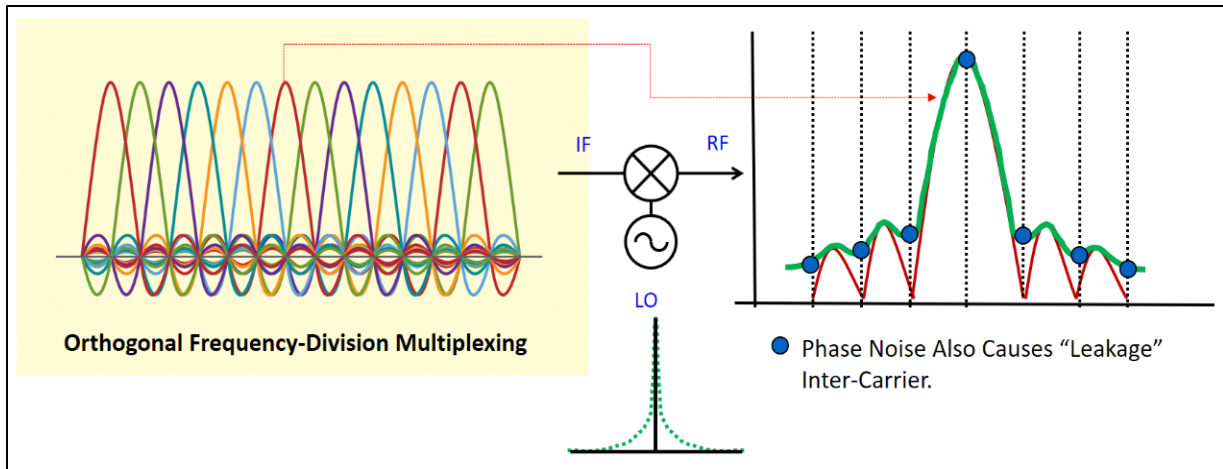

Figure 6.6: OFDM signal upconvert with a poor phase noise LO



Sophisticated signal generators allow you to adjust phase noise at the synthesizer section. This lets you degrade the phase noise performance of your signal generator and is helpful in evaluating the sensitivity of your receiver design.



Section 7. Distortion Performance

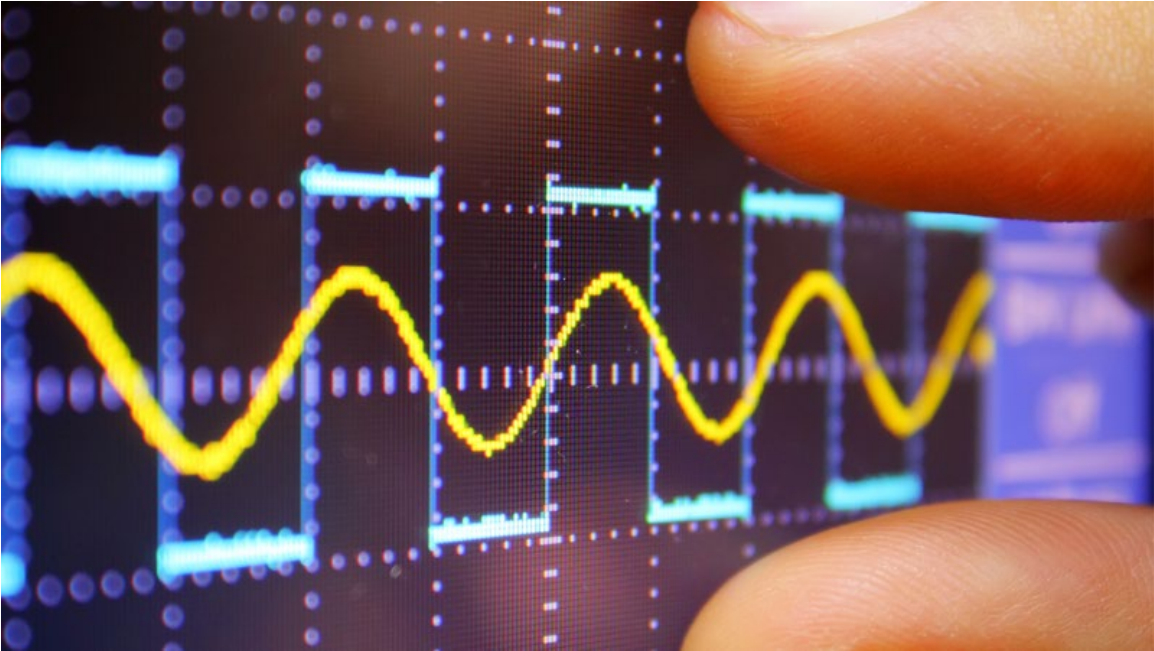

In modern wireless communications and digital radio systems, frequency channel spacing is close in order to achieve spectral efficiency. Orthogonal frequency-division multiplexing (OFDM) using a digital multi-carrier modulation scheme is common with wideband digital communication.

Testing for unwanted and nonlinear spectral distortion is critical for narrow frequency channel spacing and wide bandwidth communication systems. These distortion products are often generated from components, modules, sub-systems, and entire devices.

The distortion products could be in-channel, in-band, and out-of-band unwanted spectral signals. They degrade not only transmitter performance, but also receiver sensitivity.

Distortion can creep up in signal generators. Distortion performance is one of several major specifications of signal generators. Distortion performance can have a huge impact on device characterization. You will learn about different types of distortion and how they matter to your measurements in this chapter.

What is Distortion?

We all know what it sounds like and how unpleasant it feels to our ears. Distortions occur when you turn up the volume on digital devices. When your audio system can no longer output the full amplitude, the peaks are clipped, and you encounter harmonic distortions.

Distortion is an alteration of the original waveform. There are two major types of nonlinear distortion in signal generators: Harmonic distortion and intermodulation distortion.

- **Harmonic distortion** happens when the smooth voltage change of a pure sinusoidal wave is interrupted by an abrupt voltage change. This abrupt change is usually caused by nonlinear semiconductors. The frequencies of the harmonics are in integer multiples of the sinusoidal wave.
- **Intermodulation distortion** is a spurious output you get when mixing two or more signals with different frequencies. The spurious outputs occur at the sum and difference of integer multiples of the input frequencies.

Measuring Distortion

Harmonic Distortion

Using a continuous wave (CW) tone, we can explain how harmonic distortion is measured. Figure 7.1 shows the harmonic distortion measurement setup. The device under test (DUT) could be an amplifier or a mixer. The signal generator outputs a CW with a frequency of F_i . This CW goes through a low pass filter to remove harmonic distortions from the signal generator. Notice that the cut-off frequency of the low pass filter, F_c , is less than $2F_i$.

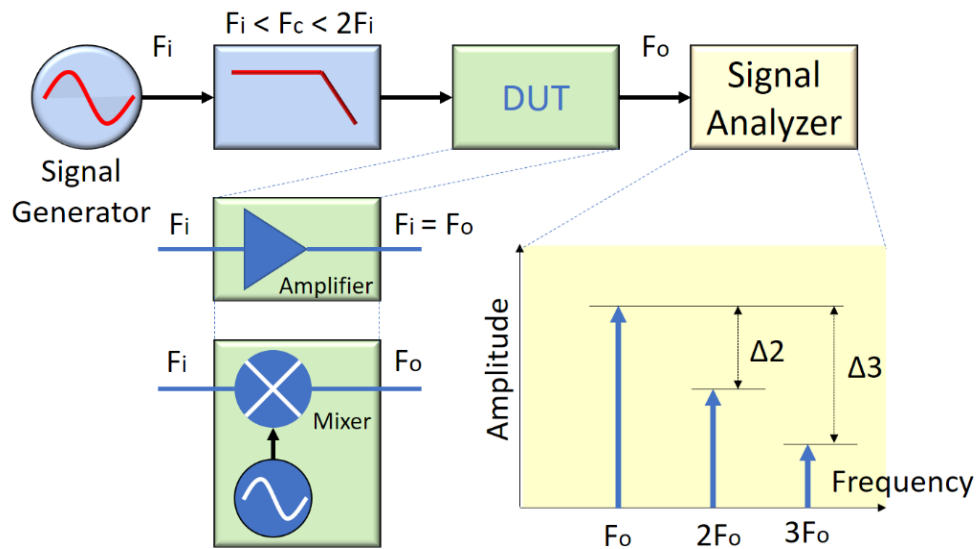

Figure 7.1: Harmonic distortion measurement setup

Harmonics are expressed as a ratio between the power in the fundamental frequency and the power in the harmonic frequency. For example, the first harmonics could be expressed as:

$$P_{1st\ harmonic} = P_{F_o} - P_{2F_o} \text{ (dBc)} = \Delta 2 \text{ dBc}$$



It's important to use a signal generator with low harmonic distortion that includes a low pass filter between the signal generator and the DUT. This ensures the measured harmonics are from the DUT rather than the signal generator.

Intermodulation Distortion - Two-Tone Intermodulation

Several techniques exist for evaluating intermodulation distortion. The simplest method for intermodulation distortion measurement is the two-tone third-order intermodulation technique, or IP3 (third-order intercept point). The IP3 technique measures the third-order distortion products generated from the non-linear elements of the DUT with a two-tone input signal.

Figure 7.2 shows the two-tone third-order Intermodulation measurement setup. The DUT could be an amplifier or mixer.

F_1 and F_2 are frequencies within the two-tone input. The two-tone signal is created by mixing two frequencies from two signal generators. The two-tone signal must be free from any third-order products. The third-order distortion products occur at frequencies $2F_1-F_2$ and $2F_2-F_1$ (in red color), which are the closest distortions to the original two-tone frequencies. Removing them with filtering proves difficult. In a communications system, they are interference signals to adjacent channels.

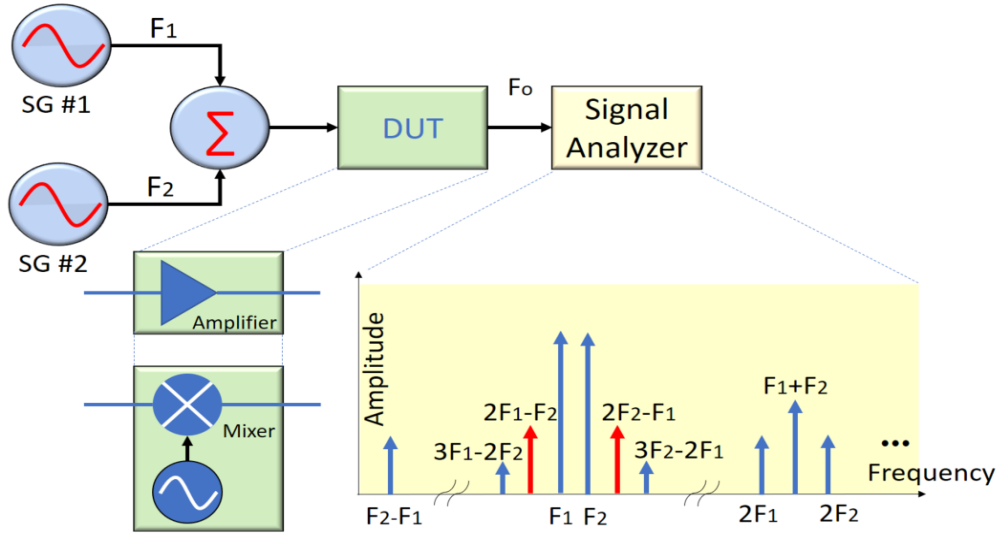

Figure 7.2: Two-tone intermodulation distortion measurement setup

Assuming the amplitudes of two test tones are equal, the IP3 is the difference between the input tones and third-order products:

$$\text{IP3 (dB)} = P_o - P_{o3}$$

where P_o is the amplitude of one of the output tones and P_{o3} (in red color) is the amplitude of third-order product on either side of the two tones.

Intermodulation Distortion - Spectral Regrowth

Wider bandwidths and multi-carrier techniques (such as carrier aggregation) are generally used to increase data throughput for the latest wireless standards. Two-tone third-order intermodulation technique cannot completely characterize the behavior of wide-bandwidth components.

Digital modulation that employs both amplitude and phase shifts generates distortion, also known as spectral regrowth. Figure 7.3 shows spectral regrowth (red area) of a digital modulation signal.

The spectral regrowth spreads outside of the main channel. An Adjacent Channel Power Ratio (ACPR) measurement is used to analyze this type of distortion. It measures the ratio of the main channel power to the power that falls into adjacent channels.

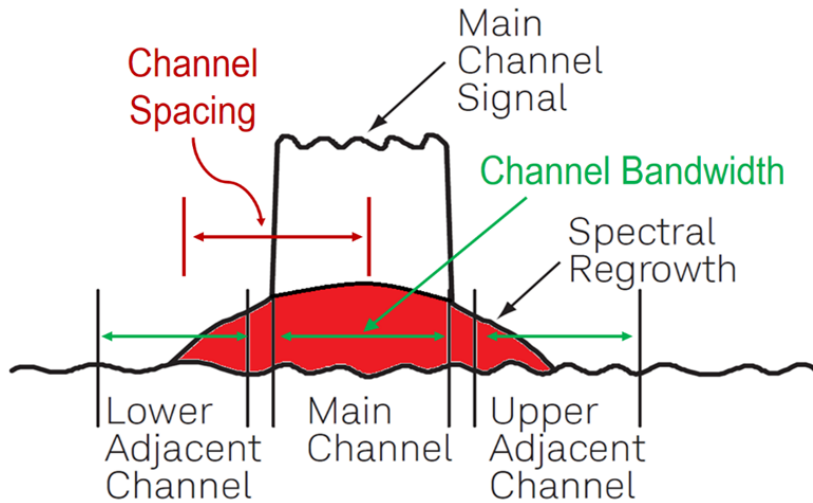

Looking to simulate distortions with your signal generator? Try our [Power Amplifier Test Signal Creation Tool](#).

Figure 7.3: Spectral regrowth of a digital modulation signal



The ACPR measurement is a key transmitter characteristic in most cellular conformance specifications. To perform ACPR measurement, you need a signal generator with ultra-low distortion performance to generate a specific standard-compliant test waveform.

Take Your Devices to the Limit

For Long Term Evolution (LTE) Evolved Node B (eNB) power amplifier test, the ACPR test requirement for R&D verification is about -60 dBc at a 10 MHz channel offset. The typical distortion performance of the N5182B is -69dBc. With minimal distortion from your generator, you will gain confidence in your ACPR measurements. Table 7.1 shows the 3GPP LTE-FDD (Frequency Division Duplexing) distortion performance of Keysight N5182B signal generator.

3GPP LTE-FDD Distortion Performance								
			Standard		Option UNV		Option UNV with 1EA	
Power level			≤ 2 dBm		≤ 2 dBm		≤ 5 dBm	
Offset	Configuration	Frequency	Spec	Typical	Spec	Typical	Spec	Typical
Adjacent 10 MHz	10 MHz E-TM1.1 QPSK	1800-2200 MHz	-64 dBc	-66 dBc	-67 dBc	-69 dBc	-64 dBc	-67 dBc
Adjacent 20 MHz			-66 dBc	-68 dBc	-69 dBc	-71 dBc	-69 dBc	-71 dBc

Table 7.1: 3GPP LTE-FDD distortion performance of the N5182B vector signal generator

Section 8. Software



Picture this. Usain Bolt, the Olympic sprinter and one of the fastest human beings on earth, steps up to the starting line. As he carefully places his feet on the starting block, he rehearses in his mind the sequence of events that will take place once the gun goes off from the first swing of his arms to crossing the finish line. However, this time is different. Usain looks nervous because he is trying to win the 100m race in high heels!

Having a high-performance signal generator without the right piece of software is like Usain Bolt racing in high heels. In this case, you will be hard-pressed to harness the full potential of the hardware. Using the right software is like wearing the right shoes to the race. You gain traction and control and are able to use the hardware's raw power to move forward and win the race.

Signal Studio

Signal Studio is a signal creation software that is integrated with Keysight signal generators. You can use it to create application-specific test signals at baseband, RF, and microwave frequencies. You can also use it to quickly generate custom reference signals for testing your device.

Signal Studio uses tree-style navigation and graphical layout, and it currently supports the latest Windows Operating System.

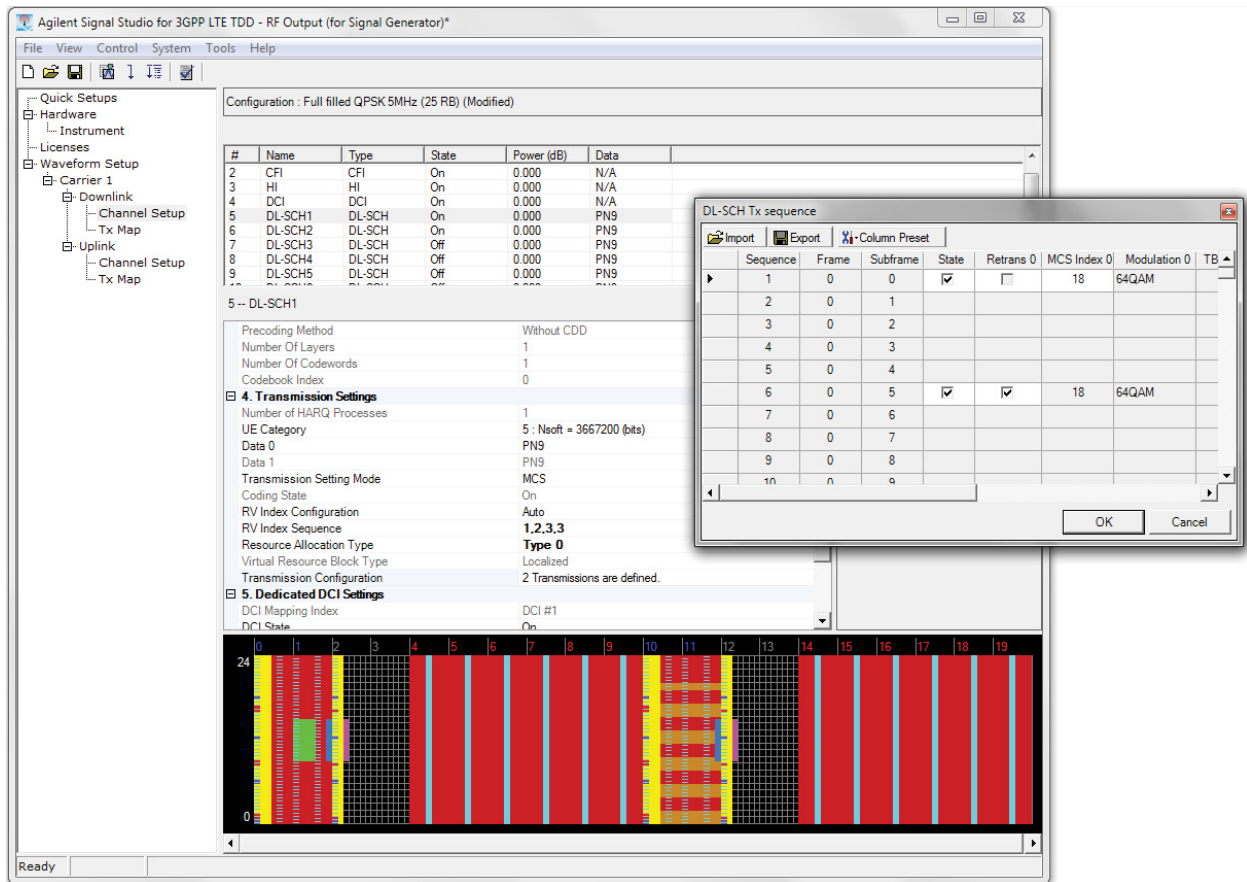

Figure 8.1: Signal Studio's tree-style navigation interface

Create Signals for Your Bench and Production Line

Signal Studio enables you to connect to your signal generator and then to your computer through Local Area Network (LAN) or General Purpose Interface Bus (GPIB). A built-in configuration tool makes the process fast and simple. The Signal Studio user interface includes a window that enables direct control of a connected instrument. For advanced automation and control, the available application programming interface (API) exposes the signal creation and generation parameters of the software. This capability also enables the generation of custom user interfaces for signal creation.

When it comes to mass production deployment, you can download waveforms created in Signal Studio to your signal generator's non-volatile memory. The software also enables you to recall and playback these waveforms using Standard Commands for Programmable Instruments (SCPI) commands or through the front panel. You can also download your custom test waveforms to multiple signal generators quickly and easily. However, you will need to be aware of licensing requirements for waveforms created using Signal Studio.



Figure 8.2: Typical component test configuration using Signal Studio with an X-Series signal generator and analyzer

Enhance Device Testing with Waveform Playback

Signal Studio's basic waveform playback capabilities enable you to create and customize waveform files needed to test components and transmitters. You can manipulate a variety of signal parameters, calculate the resulting waveforms, and download files for playback with a signal generator. The following are some of the things you can do with Signal Studio:

- Create spectrally-correct signals for channel power, spectral mask, and spurious testing
- View Complementary Cumulative Distribution Function (CCDF), spectrum, time domain, and power envelope graphs to investigate the effects of power ramps, modulation formats, power changes, clipping, and other effects on device performance
- Adjust Peak-to-Average Ratio (PAPR) with the crest factor reduction technology
- Select Signal Studio software products that enable you to save 89600 VSA or X-Series measurement application setup files for further analysis. See the appropriate technical overview of product specific information.

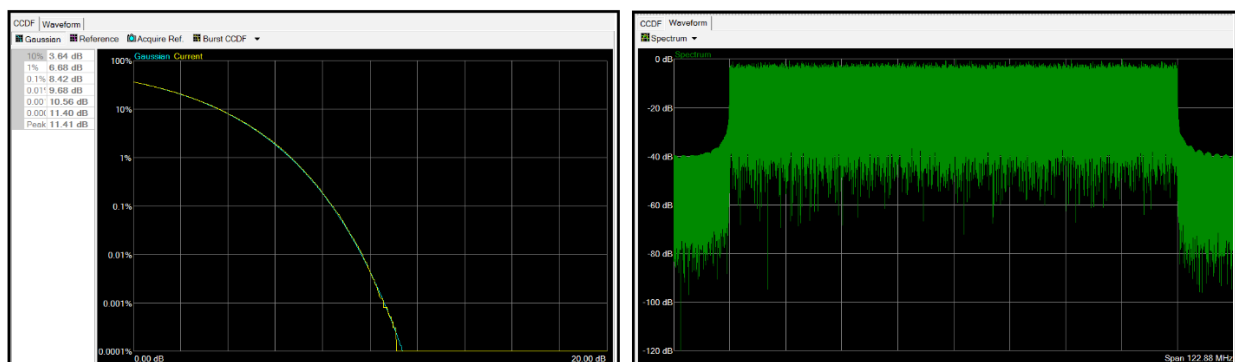

Figure 8.3: Signal Studio's CCDF and integrated spectrum view

Receiver Test with Real-time Capabilities

Signal Studio can also be used to generate standard compliant or custom signals for early testing of receiver system and component hardware with channel coding and multi-antenna ports. Evaluate receiver performance at various stages of the receiver chain (RF, IF, and IQ) on signal analyzers and/or oscilloscopes together with Keysight's 89600 VSA software, or X-Series measurement applications.

Real-time capabilities available with selected Signal Studio software provide additional features to help you create signals for tests of receiver designs in all stages of development. Advanced options enable you to create fully channel-coded signals for analysis of receiver BER, FER, BLER, and PER so that you can verify baseband subsystem coding in Application-Specific Integrated Circuits (ASICs), Digital Signal Processing (DSP)s, and more. You can also check receiver performance and functionality during RF/baseband integration, system-level test, and beyond.

Keysight Waveform Download Tools

Keysight provides download utilities to simplify downloading waveforms into the signal generator by automatically converting waveforms into the file format required by the baseband generator.

Keysight Waveform Download Assistant

The **Download Assistant software** is a free software utility that enables you to download your custom I/Q data into the baseband generator of any vector signal generator and use a single MATLAB command to play it back. In addition, you can send SCPI commands to control your signal generators from the Matlab command line.

Feature:

1. **Easy to use in MATLAB** - Use the Download Assistant's MATLAB functions to connect to the instrument, download waveform data, set parameters, and playback waveforms from the MATLAB command line. There is no need to scale or format data; the Waveform Download Assistant handles it for you.
2. **Flexible instrument control** - Send SCPI commands to control your signal generator's settings from the MATLAB command line with Waveform Download Assistant.
3. **Waveform sequencing programmable** - Create, download, and play waveform sequences using a series of SCPI commands from the MATLAB command line. An example M-file is provided to help you get started.

Keysight BenchVue Software

Keysight BenchVue is a PC-based software. You can quickly configure most commonly used measurements and setups for multiple instruments, including signal generators as shown in the left of Figure 8.4. You can select the folder of waveform files and download them to the signal generator. In addition, BenchVue includes an easy-to-use test flow to control instruments automatically as shown in the right of Figure 8.4.

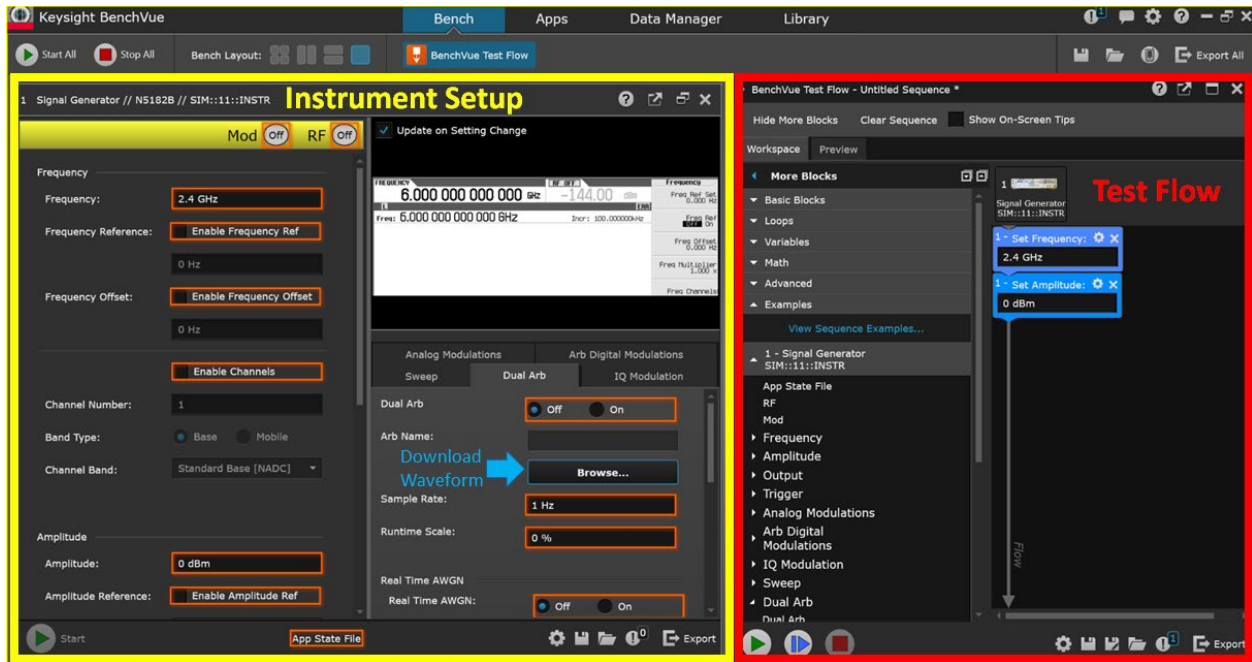

Figure 8.4: Keysight BenchVue user interface for signal generators

Programming Environment

You can use various programming environments to create and download the waveform data to the baseband generator. The programming environments include:

1. Simulation software: Matlab, Keysight SystemVue, and etc.
2. Advanced programming languages: C++, VB, VEE, MS Visual Studio.Net, Labview, etc.

You can use either the instrument's SCPI, tools' APIs, or FTP command to download waveform files to the baseband generators.

Conclusion: Building a Solid Foundation

The humble signal generator is the building block of advanced RF technologies. In 1940, the HP 200B audio oscillators helped Disney achieve sound system breakthroughs, enabling audiences around the world to enjoy the thrilling stereo sound in *Fantasia*. And now, the humble signal generator is once again helping engineers and scientists achieve breakthroughs in 5G, Multi-input Multi-output (MIMO), and radar technologies, to make our world a better place.

A better tomorrow depends upon building a solid foundation for the future trailblazers. We hope these sections have inspired you to build a solid foundation in your signal generator knowledge. Through a sound understanding of RF principles, we are able to harness the magic of RF. Now is the time for us to build on the foundation laid by those who have come before us, and to lay the path for future trailblazers.

“The scientific man does not aim at an immediate result. He does not expect that his advanced ideas will be readily taken up. His work is like that of the planter - for the future. His duty is to lay the foundation for those who are to come, and point the way.” --- Nikola Tesla

To stay up to date with the most recent tutorials, techniques, and best practices, check out the [Keysight Labs YouTube](#) channel, follow the [Keysight RF Test and Measurement Facebook](#) Page, and subscribe to our [RF and Microwave blog](#).

Learn more at: www.keysight.com

For more information on Keysight Technologies' products, applications or services, please contact your local Keysight office. The complete list is available at: www.keysight.com/find/contactus

