

# Electronic Load Fundamentals

## What is an electronic load?

An electronic load is a test instrument designed to sink current and absorb power out of a power source. If a power supply is used to power a device, an electronic load is used to test the power supply by emulating the device under test (DUT). Power supplies and electronic loads are complementary test equipment. The power supply tests electronic circuits under specific sourcing conditions. The electronic load tests the energy sources or energy conversion blocks under specific loading constraints. An electronic load is a programmable instrument that offers the user various modes of control such as constant voltage (CV), constant current (CC), constant power (CP) or constant resistance (CR). Figure 1 shows the voltage and current diagram of an electronic load.

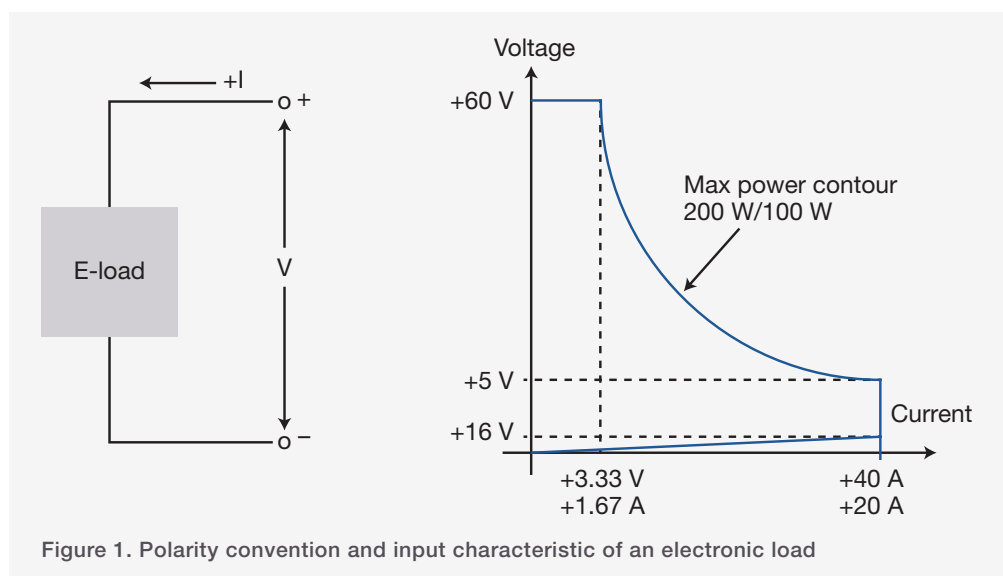

Most electronic loads specify a maximum power level they can absorb as shown by the max power contour in Figure 1. The user can operate the load only within the voltage and current combinations limited by the maximum power contour.

For example, it is not possible for an operator to sink 20 A out of a 48 V test device. Both voltage and current are within their respective ranges, while the power to absorb (960 W) falls outside the load maximum power dissipation limit of 200 W.

## Who uses electronic loads?

Device manufacturers and design engineers use electronic loads to test numerous power devices such as power supplies, DC-DC converters, chargers, adapters, batteries, solar panels, fuel-cells, and more.

## Why do engineers use electronic loads instead of a fixed value power resistor?

In situations where you need a purely resistive load and no closed loop control is required, it is sufficient to use a fixed value power resistor. A fixed value resistor presents many limitations. It is not adequate for loading and testing power sources that have complex testing requirements. Such tasks require sophisticated electronic load features to validate the various states of operation.

Adapting to changes with fixed resistors is a time-consuming task that requires many resistors, switching matrixes, and the appropriate control software. There is no way to control or limit the voltage or the current that the load consumes. The user needs to handle critical safety and device protection concerns in order to avoid any potential damage to the device.

An electronic load offers higher flexibility by allowing you to sink various levels of power profiles in multiple modes. The most common operating modes of an electronic load are constant current (CC), constant voltage (CV), constant resistance (CR), and constant power (CP).

The electronic load emulates various scenarios and actual devices that connect to your power source. An electronic load is an effective solution to test devices rather than using a fixed value resistor. A fixed resistor makes it difficult to automate and to emulate the dynamic behavior of a real device. It also makes it difficult to adapt to changes in test requirements.

# DC Electronic Load Operation Modes

## Constant current operation mode

Constant current (CC) is the most frequent mode in which an electronic load is used. In constant current mode, the load will sink the programmed current independently from the output voltage which is typically forced by the voltage source connected to it (for example a battery).

## How and where to use CC mode

Suppose you have a 3 V battery and would like to discharge it with a constant current of 1 A; see Figure 2. The operating point is the (voltage and current) setpoint where the battery output voltage intersects the programmed constant current load line of the electronic load.

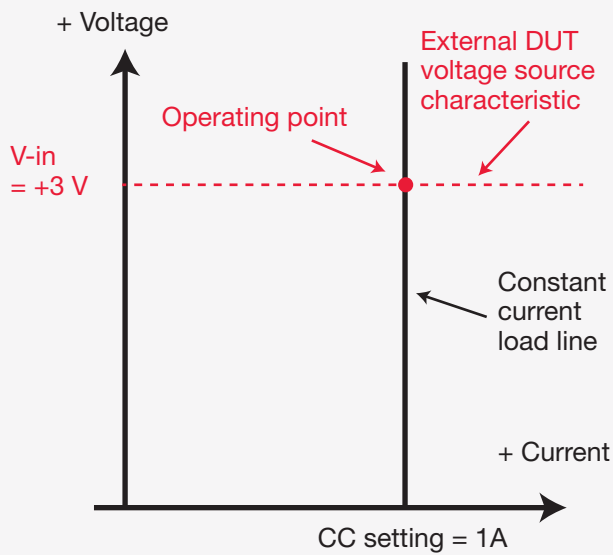

Figure 2. Electronic load I-V diagram in constant current operation

Figure 3 shows how an electronic load regulates its resistance to achieve the programmed current when it is connected to a voltage source.

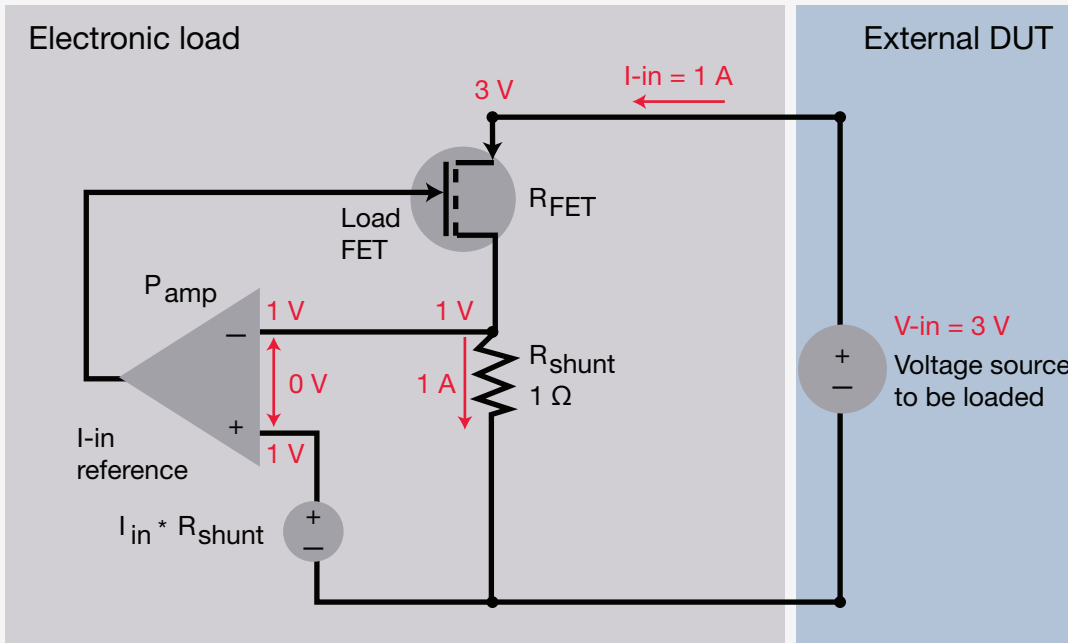

Figure 3. Electronic load circuit in constant current operation

When the load operates in CC mode, it loads the output of an external voltage source (for example, a 3 V battery), with a variable resistor to reach the desired programmed current. Most electronic loads use power transistors, FET'-s or IGBT'-s that act as a variable resistor to regulate the current flowing into the load. The transistors are typically arranged in a parallel array configuration to handle more power.

The current flowing into the load is monitored via a shunt resistor (for example 1 Ω). The voltage drop proportional to  $I \cdot R_{shunt}$  is fed to a current amplifier. The current amplifier compares the voltage drop on the current shunt against the reference programmed value (example 1 A \* 1 Ω = 1 V). The amplifier output signal regulates the FET resistance and electronic load's input current. This feedback configuration allows the load to dynamically change the resistance and maintain the programmed current independent of the voltage change of your sourcing device.

The minimum voltage where the load can sink the desired current is limited by the input current level and the low voltage behavior characteristic of the FET. Figure 4 illustrates the minimum voltage as a function of the programmable sink current for a 100 W and 200 W module with a programmable short resistance of 80 mΩ and 40 mΩ.

## Derated current detail

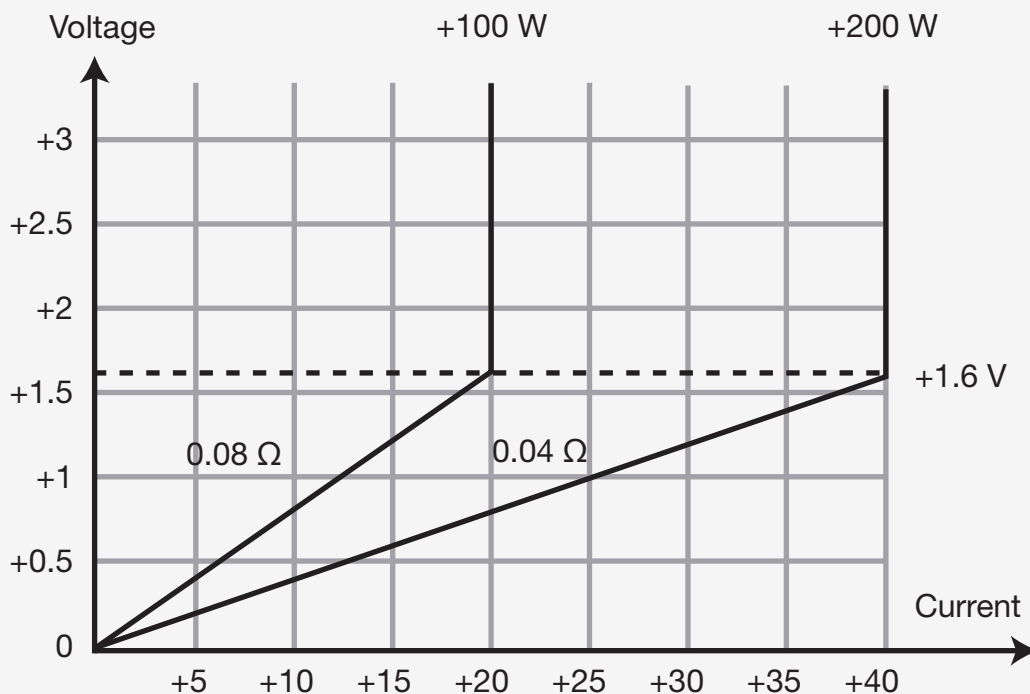

Figure 4. Minimum output voltage where the load sinks the full-scale programmed current

The ability to sink high currents at exceptionally low voltages is challenging and a highly required feature for electronic loads. Sinking at low voltages is mandatory when testing fuel cells, power management ICs, or other devices operating at low voltages and high currents. The 200 W electronic load characterized by Figure 4 offers a programmable short resistance of 40 mΩ and allows you to sink up to 1 A at an input voltage down to 40 mV and 10 A at an input voltage as low as 0.4 V.

### Constant voltage operation mode

In constant voltage (CV) mode the electronic load sets a fixed programmable voltage across its terminals independently from the input current. In CV mode, the current is set by the current source connected to it – for example, a current charging circuit or a LED current driver. The load adjusts its resistance dynamically to attain the programmed voltage at any current established by the current source under test.

## How and where to use CV mode

Testing a battery charger operating in constant current mode is an example of how you would use a load in CV mode. You can use the load as a battery sinking current to test the behavior of the charging circuit at various battery voltages corresponding to a specific state of charge.

For example, say you have a constant current charger sourcing 0.5 A and need to load it with a constant voltage of 3.8 V to emulate the charging of a lithium ion battery. The operating point is the setpoint where the current source level intersects the programmed constant voltage load line of the electronic load as shown in Figure 5.

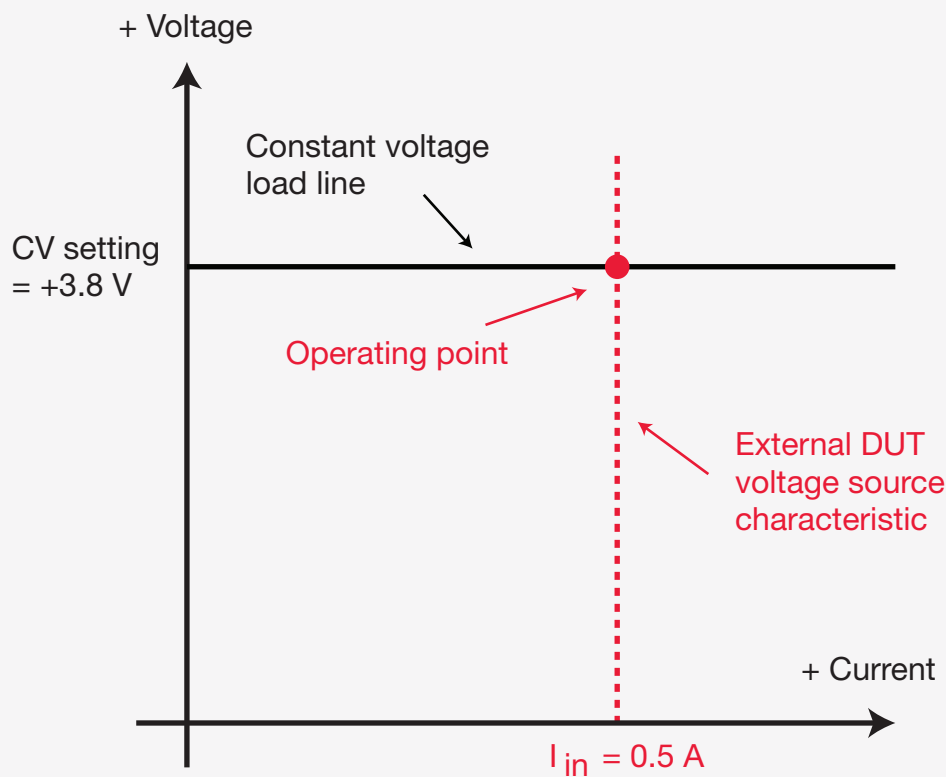

Figure 5. Electronic load I-V diagram in constant voltage operation

Figure 6. Shows how an electronic load regulates its resistance to maintain its terminal voltage when connected to a current source.

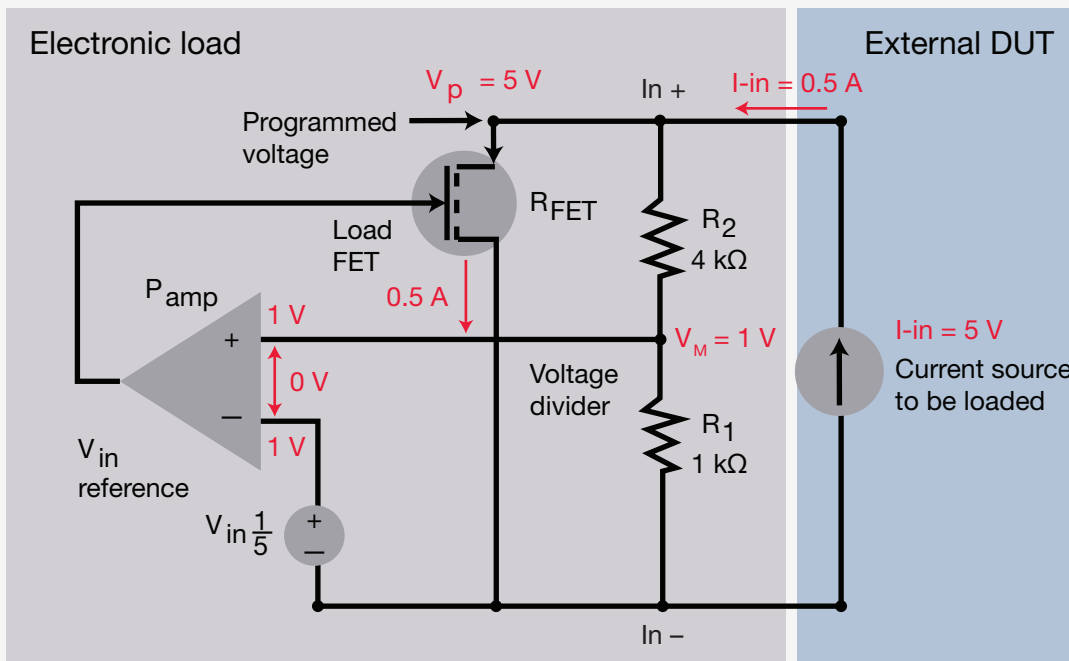

Figure 6. Electronic load circuit in constant voltage operation

The electronic load is operated in CV mode to typically test and load a current source device – for example, a current charging circuit. The electronic load modulates its resistance to reach the programmed voltage. The load monitors the input voltage through a voltage divider. The voltage amplifier compares the potential of the voltage divider (proportional to the terminal voltage) against a reference voltage (proportional to the programmed value). If the measured voltage is higher than the reference voltage, the amplifier activates the FET proportionally to decrease its resistance  $R_{FET}$  to match the programmed voltage.

This feedback configuration allows the load to dynamically change its resistance and maintain the programmed voltage regardless of the current variation of the sourcing device. The load adjusts its terminal potential for voltages and current within its range up to the maximum voltage achievable by the sourcing device.

The load regulates its terminal voltage at the programmed value if the input current remains within the current limit setting. A CV status flag indicates the output current is within the limit settings.

When the input current reaches the current limit, the load no longer operates in CV mode and the input voltage is no longer held constant. The electronic load now regulates the input current at its current limit setting. A negative current limit status flag is set to indicate that a current limit is met. If the voltage exceeds the allowable voltage or maximum power contour for the specified current, the overvoltage protection trips and the load input turns off.

## Constant resistance operation

In constant resistance (CR) mode, the load acts as a fixed programmable power resistor. An electronic load's CR mode is well-suited for loading a power source that is either a voltage or current source. When the load connects to a voltage source it sinks a current equal to the source potential divided by the programmed resistance value.

When the load connects to a current source, its terminal voltage is equal to the imposed current multiplied by the programmed resistance value. Figure 7 depicts the I-V diagram of an electronic load in CR mode when loading a voltage or current source.

A  $5\ \Omega$  load on a  $3\ \text{V}$  voltage source will result in a  $0.6\ \text{A}$  sink current. Alternatively, the same load on a  $0.6\ \text{A}$  current source results in a  $3\ \text{V}$  load voltage.

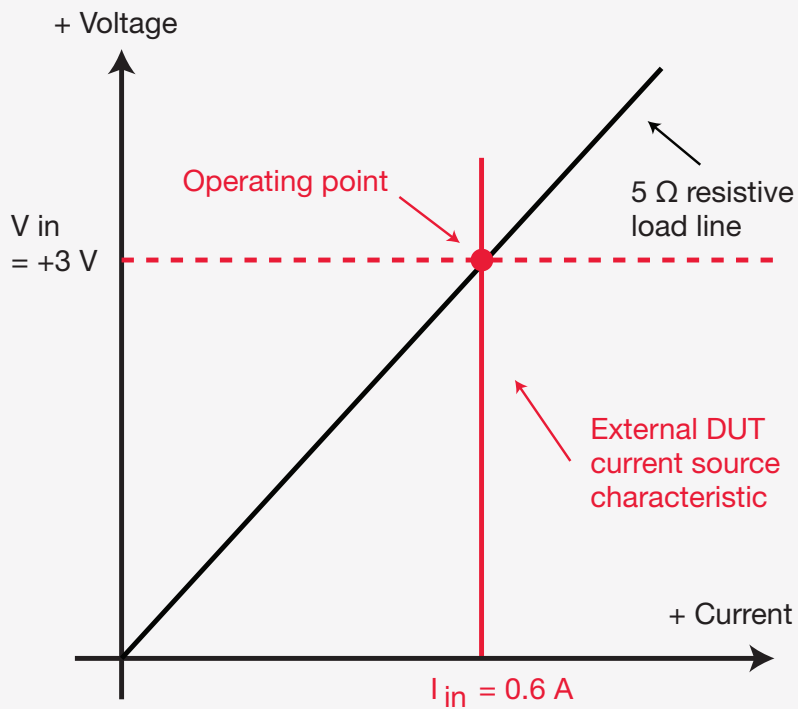

Figure 7. Electronic load I-V diagram in constant resistance operation

## How and where does an electronic load's CP mode work?

Discharging a battery with a precise resistive load for creating a specific battery profile is how you would use an electronic load in CR mode.

Figure 8. illustrates an electronic load operating in CR mode. For example, you want to load a  $5\ \text{V}$  voltage source with a  $5\ \Omega$  power resistor. In CR mode, the load needs to measure both voltage and current to adjust the FET resistance. In order to achieve a programmable resistance of  $5\ \Omega$  the ratio between voltage and current  $V / I$  should be  $5$ .



A voltage divider is necessary to measure the voltage source, while the shunt resistor measures the current. The control amplifier compares the input voltage against the input current (voltage drop on the shunt times the programmed resistance) to regulate the load input at a constant resistance value. Figure 8. shows the current sensing at 1 V / A (1  $\Omega$  shunt resistor) and the voltage sensing at 0.2 V / V (for the voltage divider). The 0 V error occurs for a current of 1 A and input resistance of 5  $\Omega$  (5 V / 1 A).

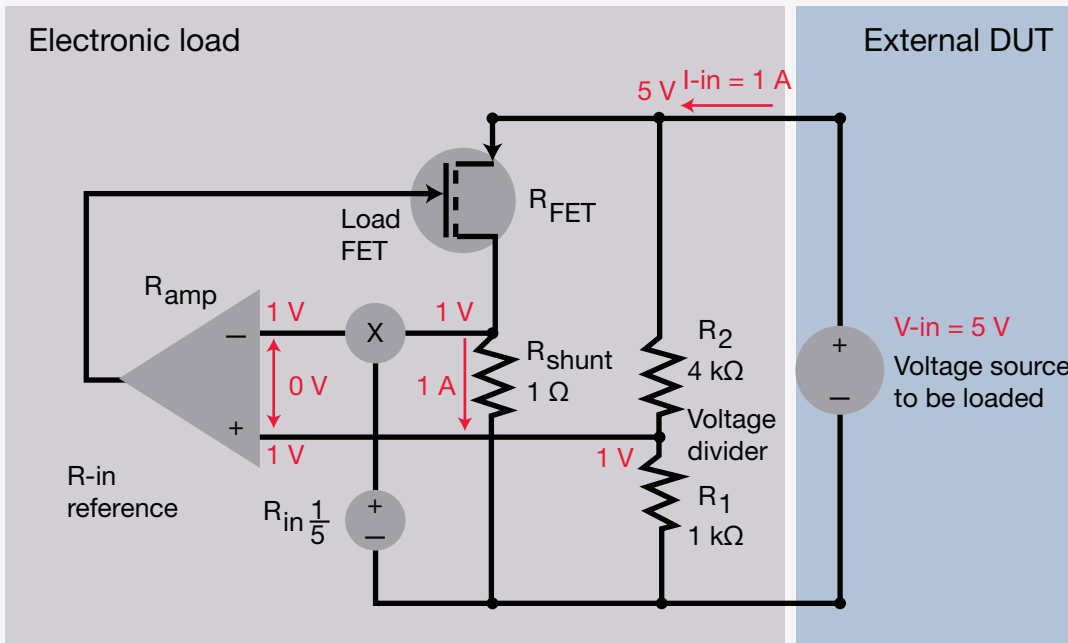

Figure 8. Electronic load circuit in constant resistance operation

If the load needs to emulate a 10  $\Omega$  resistive load on the 5 V voltage source this would result in a 0.5 A current flowing into the load. The voltage drop across the shunt is now 0.5 V. A factor of 2 is necessary to achieve the same 1 V voltage drop across the feedback amplifier. The R-in reference value that you program ( $10 \times 1/5 = 2$ ) controls the multiplying factor.

You can also program and dynamically adjust the load resistance to any value within the load range.

## Constant power operation

In constant power mode, the load module absorbs a constant power out of the DUT. It regulates the power drawn according to the programmed power value. The DUT can be either a voltage or current source. When testing a voltage source in CP mode, the load regulates the sink current to absorb the programmed power level. When testing a current source in CP mode the load regulates its terminal voltage to absorb the programmed power level.

Figure 9 shows the I-V diagram when loading a voltage source in CP mode. Loading a 5 V voltage source with 1 W constant power result in a 0.2 A sink current. In contrast, loading a 0.2 A current source with the same constant power results in a 5 V load voltage.

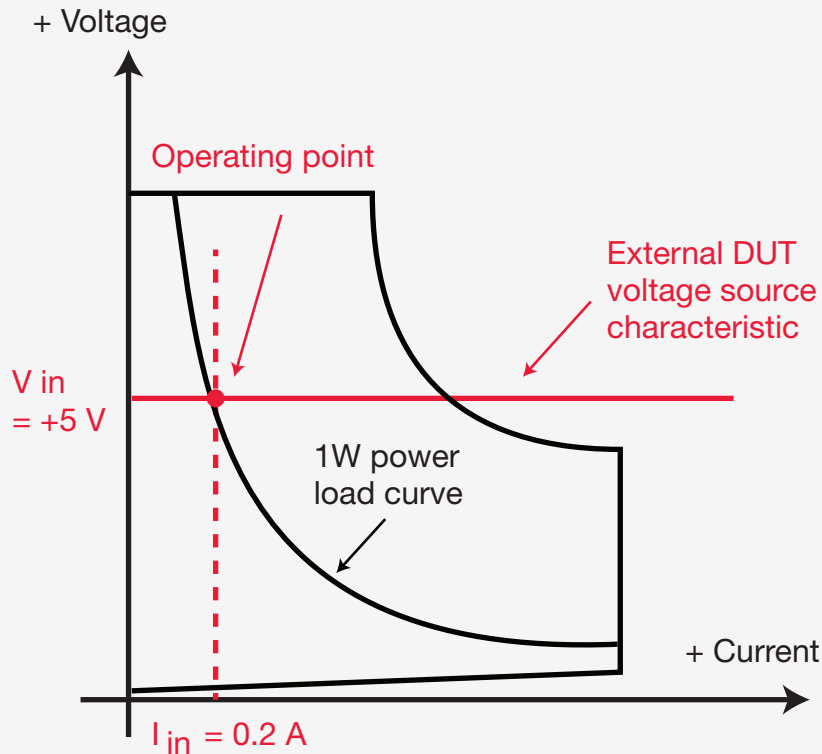

Figure 9. Electronic load I-V diagram in constant power operation

## How and where does an electronic load's CP mode work?

Discharging a battery with constant power to obtain battery life information is how you would use an electronic load in CP mode. The load discharges the battery with constant power and emulates the behavior of a DC-DC converter. Figure 10. shows the operation of the load in CP mode.

For example, if you have a 5 V battery and want to discharge it with a fixed constant power of 1 W to emulate the behavior of a Dc-to-Dc converter. The load in CP mode needs to measure both voltage and current to adjust the FET resistance to maintain a constant power of 1 W.

The load monitors the input voltage through a voltage divider, while the shunt resistor measures the current. The load measures power consumption by multiplying both voltage and current (voltage drop on the shunt). The multiplication result feeds into the control amplifier.

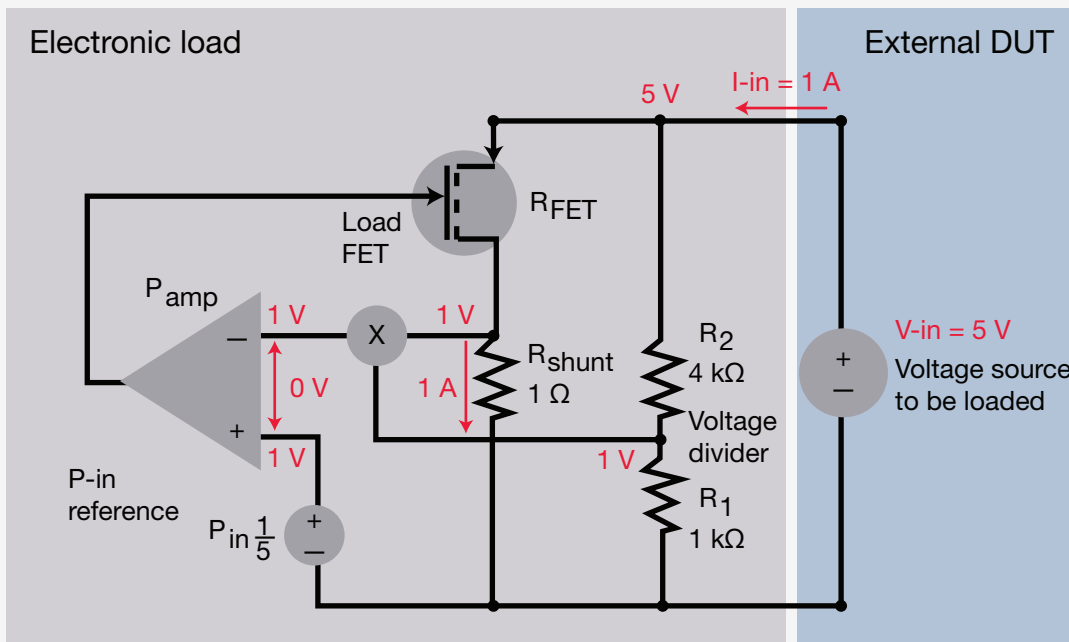

Figure 10. Electronic load circuit in constant power operation

The control amplifier compares the input power against the reference power value. The amplifier output signal regulates the FET conductance that controls the current flowing into the load. If the power measurement is lower than the reference power, the amplifier activates the FET proportionally. The FET increases its conductance (current flowing into the load) to match the power reference power level.

The feedback configuration allows the load to dynamically change its resistance/ conductance to adjust the sink current. It maintains the same power consumption level regardless of the voltage variations of the sourcing device. The maximum power the load can consume at low voltages is limited by the source voltage and the load minimum programmable short resistance  $V^2/R_{\text{short}}$ .

Discharging a battery with constant power gives you battery life information. It allows you to understand how the Dc-to-Dc converter discharges the battery in similar conditions. A battery voltage usually decreases during discharge. The load in CP mode sinks additional current to keep the power consumption constant.

For example, to discharge the 5 V battery down to 4 V in 1 W CP mode results in an initial discharge current of 0.2 A. When the battery voltage decreases to 4 V the discharge current increases up to 0.25 A.

## E-load Applications

As technology advances, electrification of legacy mechanical drive energy significantly increases the use of electrical power. Designers are racing to produce high energy-efficient products. Rigorous testing on power source and power consumption devices are increasing DC electronic load applications.

The following are typical applications and how electronic loads are used across various industries:

	Description
	<b>Power converter and inverter testing:</b> This is a fast way to test DC-DC and AC/DC converters. The electronic load helps to simulate the power-on process of the device. You can test the minimum and maximum input turn-on voltage level with different load levels. You can carry out ripple, noise, load/line regulation, over voltage, and current protection tests with the electronic load.
	<b>Uninterruptible power supply (UPS):</b> This is a complete test that requires an AC source, DC source, DC load, and AC load. The DC load uses the load bank to test the backup battery and charger within the UPS. An AC load tests the entire UPS system. A load bank test indicates the UPS's ability to provide the necessary power, voltage stability, and efficiency of control systems under varying load conditions.
	<b>Batteries and fuel cells:</b> Use constant loading to reduce the test time in comparison to resistor load banks. To test the capacity, use the CP mode to provide a consistent power drain as the battery voltage drops over time. The electronic load's capability to program different load profiles with a fast transition enables profile testing for battery charge and discharge cycles.
	<b>Solar panels:</b> This is a good solution for high-power photo voltaic testing as solar panels can sink high current at a lower cost. Use the CV mode to capture the I-V curve and incremental voltages to measure the current. With portable devices, program the e-load to simulate various device power states such as sleep, power conservation, and full power modes for a power consumption test.
	<b>Portable devices:</b> Use the electronic load to simulate various device power states such as sleep, power conservation, and full power modes to test power consumption.

# How to Select the Right Electronic Load

Use these guidelines to help select an electronic load that best fits your test requirements.

- Form factor
  - Choose a modular, small form factor solution to give you the flexibility to scale for future expansion for automated test equipment (ATE).
- Capacity rating
  - Ensure your electronic load safely manages the capacity of your power source.
  - Check that the electronic load range of operations cover your maximum voltage, current and power requirements.
- Speed
  - Choose a load to emulate fast waveforms with the appropriate slew rate.
  - Verify the load can generate and measure the signals of your application with adequate bandwidth.
  - Choose a load with a programmable slew rate and ON|OFF delays to control sequencing.
  - Select a load with superior command processing time and output speed to improve and maximize your system throughput.
- Operating modes
  - CC for a power consumption test
  - CR for replacing a resistor
  - CV to test current source
  - CP to test storage capacity
- Dynamic testing
  - Identify a dynamic load with arbitrary function generation capabilities and built-in waveforms to test sine, pulse, step, ramp, or to import your profiles.
  - Ensure the load has sufficient sample rate to generate/ measure fast transient signals and sufficient memory.
  - Verify the load generates the arbitrary dynamic waveforms for necessary modes,
- Flexibility
  - Choose a modular system to mix and match different modules – electronic load and power modules – within the same unit.
  - Synchronize within a single environment to achieve a turnkey solution.
- Protection features
  - Confirm the load has built-in protection features for overvoltage, overcurrent, overpower, and overtemperature.
  - Ensure shut down features to avoid hazardous conditions on your DUT.
- Computer control
  - Load connectivity interfaces for remote programming and controlling of your instrument – GPIB, LAN, or USB.

## Flexible Load Solutions for Automated Test Equipment

The Keysight N6790 Series DC electronic loads give you the flexibility to test power supplies in a 1U footprint. The built-in measurement system offers you accuracy and convenience. It eliminates the need for a digital multimeter (DMM), external shunts, and wiring. The N6790A electronic load modules fit within a low profile for the N6700/01/02C mainframe with 1U of rack space. The mainframe offers side air vents; it does not have top or bottom air vents. Other instruments are mounted directly above or below.

The mainframe hosts up to four electronic load modules making the N6790 series an ideal solution for automatic test equipment (ATE) systems, design validation, and manufacturing. The low profile mainframes give system designers the flexibility to mix and match different electronic loads and power modules within a single unit.



N6700/01/02C low profile high-density system solution

## Benchtop Loads

The N6705C DC Power Analyzer provides unrivaled productivity gains for loading, sourcing, and measuring DC voltage and current into the DUT. The system integrates up to four load modules with a digital multimeter (DMM), scope, arb, and data logger features. The N6705C eliminates the need for additional equipment for creating complex test setups, including transducers. You can easily eliminate current probes and shunts to measure the current into your DUT.

The DC power analyzer also eliminates the need to develop custom programs to control multiple instruments. All functions and measurements are available at the front panel. Keysight's 14585A control and analysis software offers control and analysis functions. When automated bench setups are necessary, the N6705C is fully programmable over GPIB, USB, LAN and is LXI-compliant.



N6705C high-density bench solution

## High Power DC Electronic Loads

Keysight's N3300A modular load solution helps you with higher power requirements. The N3300A is a full-rack width mainframe with 6-slots. It accepts combinations of N330xA user installable load modules (150 W to 600 W). The modular design provides easy system configuration and future reconfigurations. The N3300A also allows up to 1,800 watts of total maximum power.

All outputs are measured simultaneously using the built-in measurement capabilities with multiple single output power sources. The N330xA Series of DC electronic loads gives you fast operation, accurate programming and read-back necessary for high volume DC power supply test systems.



N3300A High power system solution

## Summary

Testing the reliability of a power source or the efficiency of an energy conversion block is a crucial step for various industries to ensure that the devices meet the required compliance standards. Multiple devices with complex loading profiles require a high density test system with advanced features. An electronic load is a programmable instrument that offers various modes of control such as constant voltage, constant current, constant power, and constant resistance. It comes in different footprints ideal for automatic test equipment (ATE) systems, design validation, and manufacturing. It emulates various scenarios and actual devices that connect to your power source. An electronic load provides higher flexibility by allowing you to sink various levels of power and arbitrary profiles. An electronic load is an effective solution to test power devices. It reduces test time and cost by easily adapting to continuous changes in device test requirements.

Learn more at: [www.keysight.com](http://www.keysight.com)

For more information on Keysight Technologies' products, applications or services, please contact your local Keysight office. The complete list is available at: [www.keysight.com/find/contactus](http://www.keysight.com/find/contactus)

